

DESIGN PRO

3967 East Calvary Road
Duluth, MN 55803

P: 218-728-9481
F: 218-728-1730
www.designproforms.com

LANDSCAPE BLOCK ENGINEERING

CONTENTS

ENGINEERING SPECIFICATIONS AND ASSUMPTIONS

I. Preface	1
II. Material and Soil Properties Assumed.	1

INSTALLATION SPECIFICATIONS AND PROCEDURE

I. Concrete	2
II. General	2
III. Execution	3

CONSTRUCTION DRAWINGS

I. Block dimensions	5
II. 6' unreinforced wall height	6
III. 8' wall height	6
IV. 20' wall height	7

I. PREFACE

- A. Assumptions were made to provide Design Pro Inc. with an approximate retaining wall height(s). These wall height(s) were calculated using assumed soil and material properties and may vary from location to location of specific jobs. Since soil conditions vary greatly from site to site, an engineering analysis should be performed on each wall installation.

II. MATERIAL AND SOIL PROPERTIES ASSUMED

A. BACKFILL SOIL

1. Soil Type Poorly graded sand and gravel well drained, class SP
2. Soil Unit Weight 110 pcf
3. Internal Soil Friction Angle 30 deg
4. Wall-Soil Friction Angle 20.1 deg

B. BASE SOIL

1. Soil Type Gravel well drained and compacted
2. Soil Unit Weight 125 pcf
3. Internal Soil Friction Angle 38 deg

C. CONCRETE BLOCK

1. Unit weight 150 pcf
2. Average Compressive strength 3,000 psi
3. Concrete/Soil Friction Factor 0.67

D. FACTOR OF SAFETY ASSUMPTIONS

1. FS for wall Sliding 1.5
2. FS for overturning - 2.0
3. FS for Bearing Capacity 3.0

I. CONCRETE

- A. All concrete will be mixed to achieve a minimum 3,000 psi compressive strength in 28 days. In areas of freeze/thaw cycles, adequate protection by air-entrainment must be provided as determined by the Engineer.

II. GENERAL

- A. Work shall consist of construction of a Retaining Wall System in accordance with these specifications and in reasonably close conformity with the lines, grades, design, and dimensions shown on the plans.
- B. Work includes furnishing and installing geogrid soil reinforcement of the type, size, location, and lengths designated on the construction drawings.
- C. Base Leveling Pad Material shall consist of a compacted crushed stone base or non-reinforced concrete as shown and specified on the construction drawings.
- D. Unit Drainage Fill shall consist of clean 1" minus crushed stone or crushed gravel meeting the following gradation tested in accordance with ASTM D-422:

<u>Sieve Size</u>	<u>Percent Passing</u>
1 inch	100
3/4 inch	75-100
No. 4	0 - 10
No. 50	0 - 5

- 1. One cubic foot, minimum, of drainage fill shall be used for each square foot of wall face. Drainage fill shall be placed between and behind units to meet this requirement.
- E. Reinforced Backfill shall be free of debris and meet the following gradation tested in accordance with ASTM D-422.

<u>Sieve Size</u>	<u>Percent Passing</u>
2 inch	100-75
3/4 inch	100-75
No. 40	0-60
No. 200	0-35

- 2. The maximum aggregate size shall be limited to 3/4 inch unless field tests have been performed to evaluate potential strength reductions to the geogrid design due to damage during construction.
 - 3. Material can be site excavated soils where the above requirements can be met. Unsuitable soils for backfill (high plastic clays or organic soils) shall not be used in the backfill or in the reinforced soil mass.
 - 3. Contractor shall submit reinforced fill sample and laboratory test results to the Owner's Engineer for approval prior to the use of any proposed reinforced fill material.
- F. Geogrid Soil Reinforcement shall consist of high tenacity geogrids or geotextiles manufactured specifically for soil reinforcement applications. The type, strength and location shall be shown on the construction drawings.
- G. Drainage collection pipe shall be a perforated or slotted, PVC or corrugated HDPE pipe. The pipe and drainage aggregate may be wrapped with a geotextile fabric that will function as a filter. Drainage pipe shall conform to ASTM D-3034 and/or ASTM D-1248.

III. EXECUTION

A. Excavation

1. Contractor shall excavate to the lines and grades shown on the construction drawings. Owner's representative shall inspect the excavation and approve prior to placement of leveling material or fill soils. Proof roll foundation area as directed to determine if remedial work is required.
2. Following excavation for the leveling pad and/or reinforced soil zone, the soil shall be examined by the Owner's Engineer to assure the actual foundation soil strength meets or exceeds the assumed designed bearing strength. Soils not meeting the required strength shall be removed and replaced with soil meeting the design criteria, as directed by the Owner's Engineer.

B. Base Leveling Pad

1. Leveling pad material shall be placed to the lines and grades shown on the construction drawings, to a minimum thickness of 6 inches and extend laterally a minimum of 6" in front and behind the concrete wall unit.
2. Soil leveling pad materials shall be compacted to a minimum of 95 % of the maximum Standard Proctor density per ASTM D-698.
3. Leveling pad shall be prepared to insure full contact to the base surface of the concrete units.

C. Modular Unit Installation

1. First course of units shall be placed on the leveling pad at the appropriate line and grade. Alignment and level shall be checked in all directions and insure that all units are in full contact with the base and properly seated.
2. Place the front of units side-by-side. Do not leave gaps between adjacent units. Layout of corners and curves shall be in accordance with manufacturer's recommendations.
3. Place and compact drainage fill within and behind wall units. Place and compact backfill soil behind drainage fill. Follow wall erection and drainage fill closely with structure backfill.
4. Maximum stacked vertical height of wall units, prior to unit drainage fill and backfill placement and compaction, shall not exceed one course.

D. Structural Geogrid Installation

1. All materials shall be installed at the proper elevation and orientation as shown in the wall detail on the construction plans or as directed by the Owner's Engineer. The wall units and geosynthetic reinforcement shall be installed in general accordance with the manufacturer's recommendations.
2. Geogrid shall be oriented with the highest strength axis perpendicular to the wall alignment.
3. Geogrid reinforcement shall be placed at the strengths, lengths, and elevations shown on the construction design drawings or as directed by the Owner's Engineer.
4. The geogrid shall be laid horizontally on compacted backfill and attached to the concrete wall units. Place the next course of modular concrete units over the geogrid. The geogrid shall be pulled taut, and anchored prior to backfill placement on the geogrid.

5. Geogrid reinforcements shall be continuous throughout their embedment lengths and placed side-by-side to provide 100% coverage at each level. Spliced connections between shorter pieces of geogrid or gaps between adjacent pieces of geogrid are not permitted.

E. Reinforced Backfill Placement

1. Reinforced backfill shall be placed, spread, and compacted in such a manner that minimizes the development of slack in the geogrid and installation damage.
2. Reinforced backfill shall be placed and compacted in lifts not to exceed 6 inches where hand compaction is used, or 8 - 10 inches where heavy compaction equipment is used. Lift thickness shall be decreased to achieve the required density as required.
3. Reinforced backfill shall be compacted to 95% of the maximum density as determined by ASTM D698. The moisture content of the backfill material prior to and during compaction shall be uniformly distributed throughout each layer and shall be dry of optimum, + 0%, - 3%.
4. Only lightweight hand-operated equipment shall be allowed within 3 feet from the soil side of the modular concrete unit.
5. Tracked construction equipment shall not be operated directly upon the geogrid reinforcement. A minimum fill thickness of 6 inches is required prior to operation of tracked vehicles over the geogrid. Tracked vehicle turning should be kept to a minimum to prevent tracks from displacing the fill and damaging the geogrid.
6. Rubber tired equipment may pass over geogrid reinforcement at slow speeds, less than 10 MPH. Sudden braking and sharp turning shall be avoided.
7. At the end of each day's operation, the Contractor shall slope the last lift of reinforced backfill away from the wall units to direct runoff away from wall face. The Contractor shall not allow surface runoff from adjacent areas to enter the wall construction site.

E. As-built Construction Tolerances

1. Vertical alignment - 1.5" over any 10 ft. distance.
Wall Batter - within 2 degrees of design batter.
2. Horizontal alignments $\pm 1.5"$ over any 10 ft. distance. Corners, bends, curves ± 1 ft. to theoretical location.
3. Maximum horizontal gap between erected units shall be 1/2 inch.

F. Field Quality Control

1. The Owner shall engage inspection and testing services, including independent laboratories, to provide quality assurance and testing services during construction. This does not relieve the Contractor from securing the necessary construction control testing during construction.
2. Testing and inspections services shall only be performed by qualified and experienced technicians and engineers.
3. As a minimum, quality assurance testing should include foundation soil inspection, soil and backfill testing, verification of design parameters, and observation of construction for general compliance with design drawings and specifications.

I. BLOCK DIMENSIONS

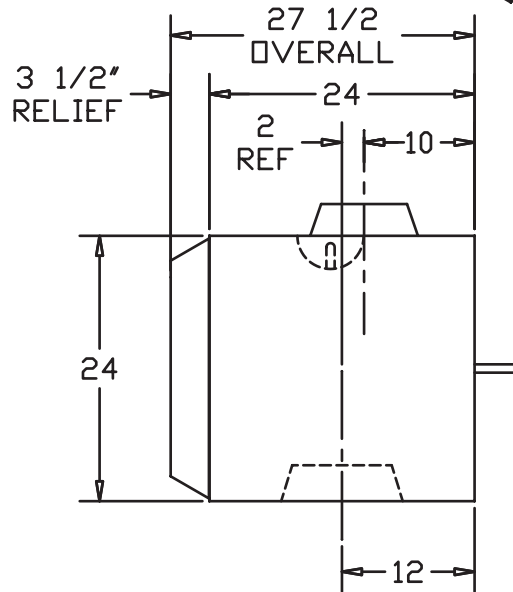
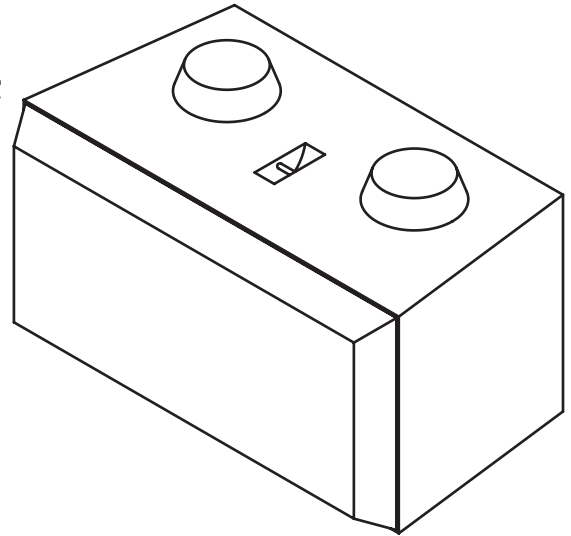
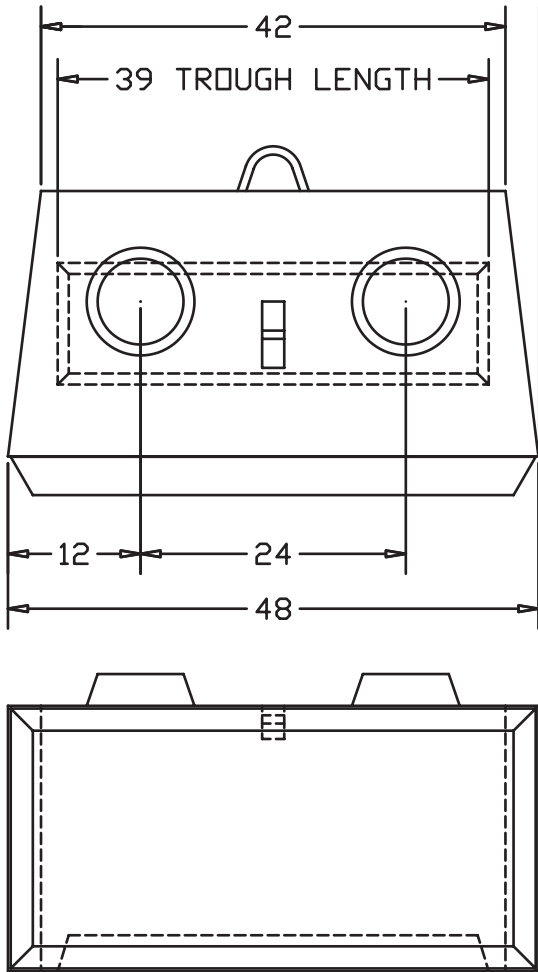

II. 6' UNREINFORCED WALL HEIGHT

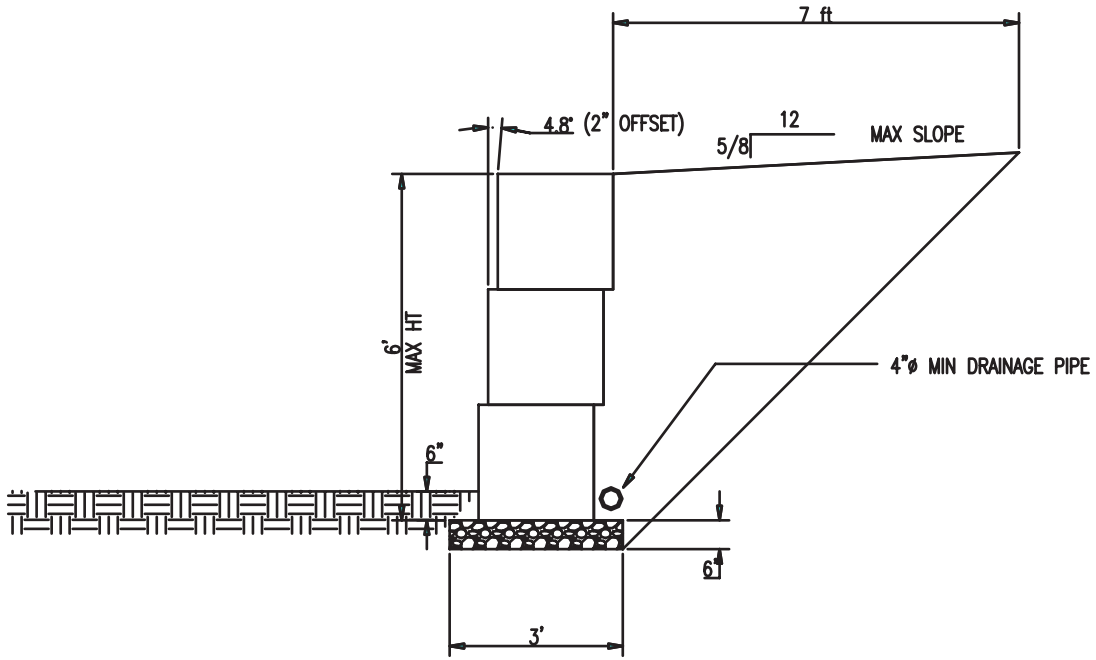

NO SOIL REINFORCEMENT USED

III. 8' WALL HEIGHT

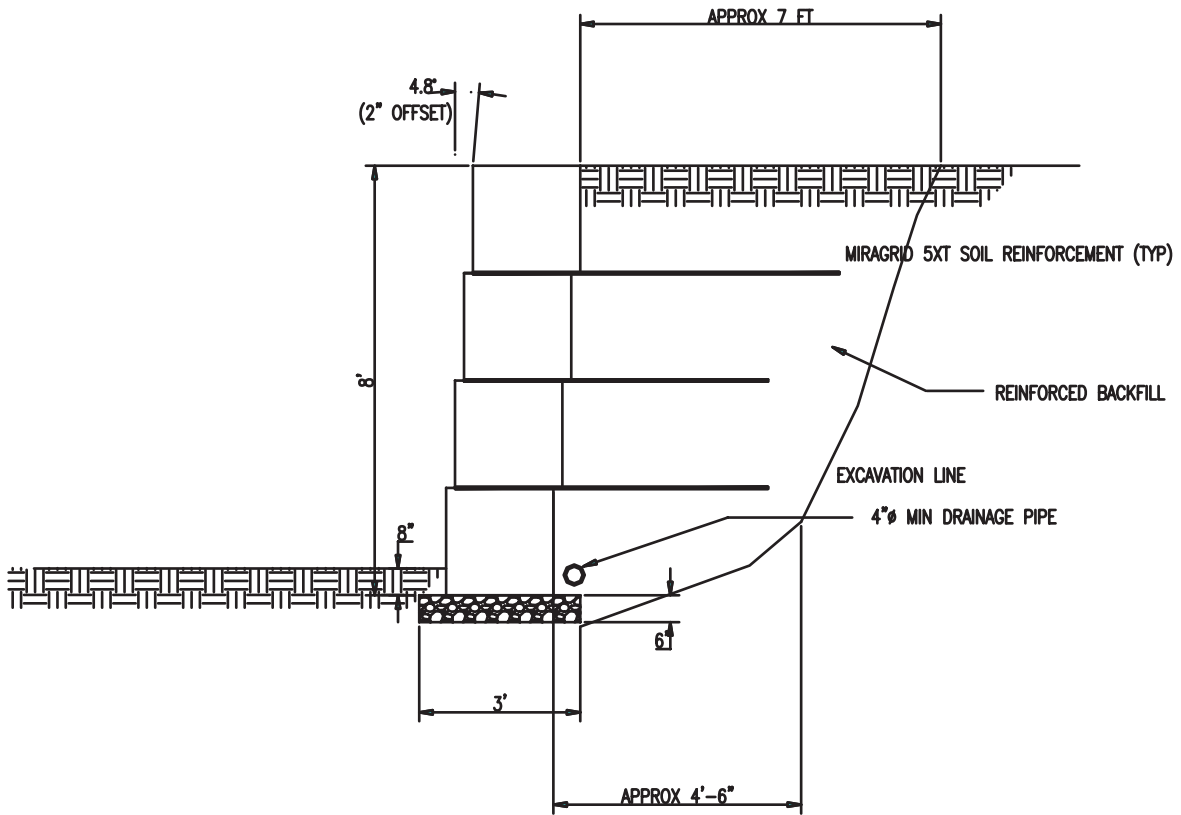

SOIL REINFORCEMENT USED

IV. 20' WALL HEIGHT

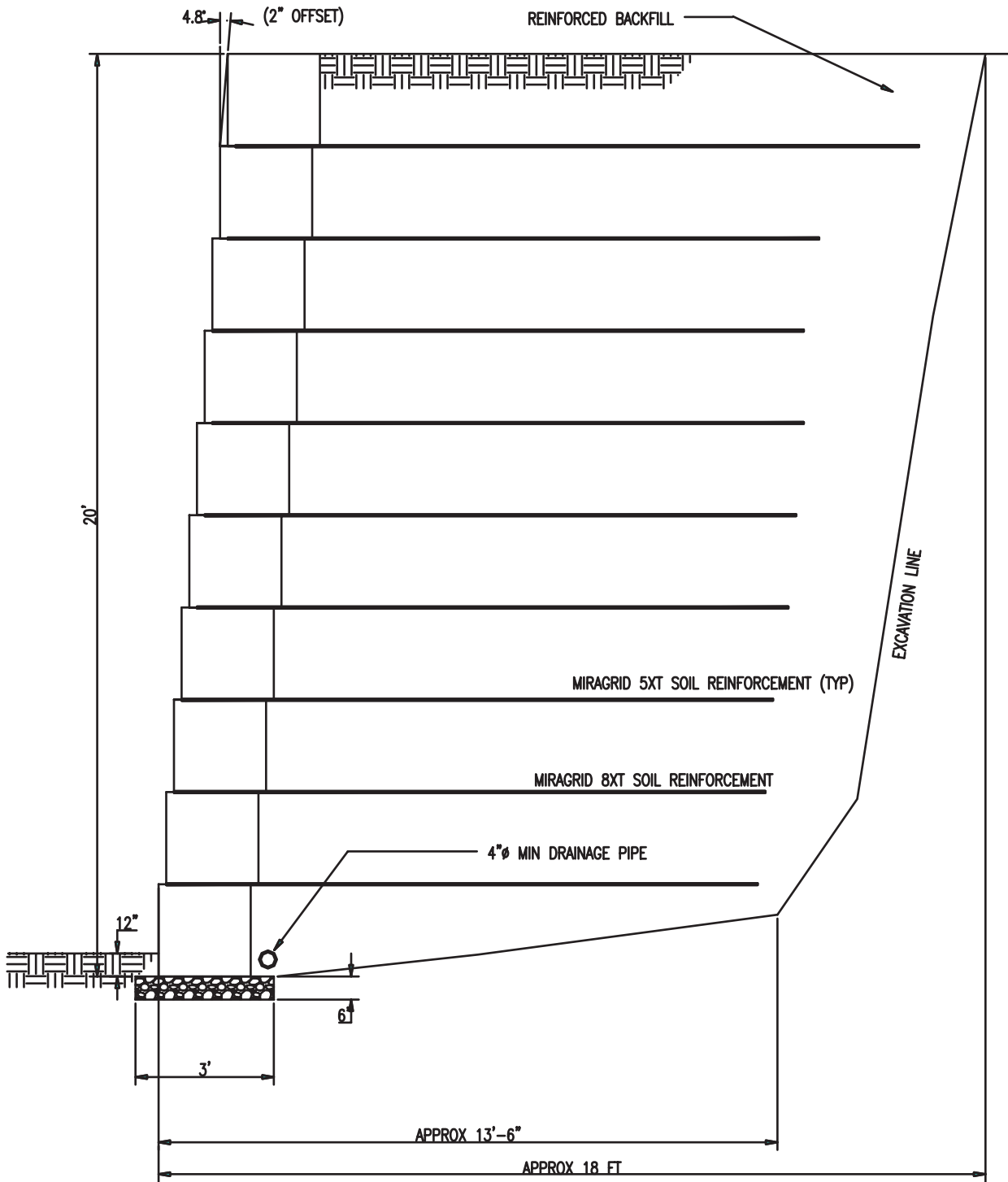

SOIL REINFORCEMENT USED